



Meeting Notes
ACEC-Missouri
KCMO Liaison Committee Meeting
 Wednesday, November 9, 2022
 4:00-5:00 pm
 Virtual and Burns & McDonnell WHQ

ATTENDEES:

<u>KCMO Representatives</u>	<u>ACEC-MO Liaison Committee Representatives</u> (parenthesis denote term end year)
Jason Waldron	Nathan Hladky (23)
Nick Bosonetto	Kristen Leathers-Gratton (23)
Mark Montgomery	Agnes Otto (23)
Angie Laurie	Rob Krewson (24)
Bailey Waters	Julie McNiff* (24)
Michael Gawlick	Tom Poer (24)
Matthew Muckenthaler	Jeff McKerrow (25) (unable to attend)
Sherae Honeycutt	Laura Gray* (25)
	Chip Touzinsky (for Jeff McKerrow)
	Jen Bernardi

*virtual

1. Welcome & Introduction

Prior to convening this first meeting of the returning and newly seated committee members it was determined that we would do a deeper dive with KCMO Public Works rather than follow a more traditional report out across City departments. We will work with the committee and City department leads to establish the next meeting.

2. Safety Moment

Our safety moment focused on the importance of quality processes and performance in our industry and the celebration of World Quality Month.

3. KCMO Public Works

a. Jason Waldron – Transportation Director

- Jason presented the update organizational chart for Public Works. (See attached chart and Power Point.)
 1. The department has been reorganized so that Jason reports directly to Public Works Director, Michael Shaw. Now driving to be “a department of solutions.” Three major departments – Engineering, Construction, Multimodal – are led by managers reporting directly to Jason.

2. Prioritization of initiatives and bringing in new faces to get the work done have been the major focus.
 3. KCMO could use the industry's support in advocating for grants to not only build new infrastructure, but to maintain what exists.
 4. Important facts about the scope and reach of the KCMO transportation network are shared in the Power Point.
- Big Initiatives:
 1. Streetcar expansions
 2. Vision Zero
 3. Protected Bike Lanes (~30 miles)
 4. Street Resurfacing (more miles than ever before)
 5. Highway 71/Bruce R. Watkins (community led first phase of the project)
 - Challenges/Opportunities:
 1. Recruitment – more staff is needed with strong technical experience.
 2. Project Support.
 3. Grants – the City is getting more aggressive and proactively chasing grants, exploring opportunities to get grants and help utilize them once won.
 4. Internships – the City is working to bolster their program to be competitive with private industry.
 - There has been a shift in philosophy for the City with neighborhoods and communities dictating how the roads look instead of the other way around.

b. Nick Bosonetto – City Engineer

- Nick has been with the city about 10 months.
- Highlights:
 1. The City has 100,000 streetlights that are being converted to LED to save money.
 2. Asset Management – KC is a large city with many assets. The City is working to collect the information about where assets are located and what condition they are in.
 3. City is recertified with APWA.
 4. Right-of-Way – city acquires their own ROW.
 5. Project Controls – currently 327 active projects – see PPT for software information.
 6. Capital Projects – 152 of the 327 are Capital Projects, over \$700 million in the works. Many of these projects are bridges or realignment/reconstruction of roadway

c. Angie Laurie – Associate Director Transportation (Multi-Modal)

- Multi- Modal – Angie has been in the role almost a year and with the city almost 4 years.
- Most of the team has been there less than 4 years, opportunity for a lot of learning, team includes both planners and engineers.
- Streetcar – Main St. is past 31st, Riverfront is almost to 100% design. The East/West Connections study (31st/39th) and North Extension study are underway. City is the owner of the system, daily coordination with the

Streetcar Authority. Day-to-Day looks like safety and security oversight. Completed the annual report to FTA (funding, costs, operations/maintenance).

- City is the largest funder of the KCATA for bus transportation, constant efforts to improve (shelters, trash cans)
- Bike/ped – Vision Zero Action Plan, Traffic Calming in 50 locations, 19 miles of protected bike lanes, Micromobility – management and coordination, Intersection Safety Improvements (6 pilot locations)
- Scooter pilot program – ideally ready for RFP process in the spring, both within the city and also adjacent communities (MARC)
- Traffic – (Transportation Planning, Traffic Engineering) Signal Improvements at 63rd and Ward Pkwy, 855 signals are managed under the Traffic Signal System Management
- Parking – Management of on-street spaces (40-50K), garages (city owns 8), 2 surface lots, working on meter updates, coordination with police under new Council legislation (11/1)

d. Mark Montgomery – Associate Director Construction

- 11,000 permits issued in 2022
- Permits needed for any incursion into the public ROW.
- Materials Lab – in house testing availability
- Sidewalk and Neighborhood Design and Inspection – 2 PMs and over 89 projects slated for completion before May 2023.
- Currently 10 firms on the on-call inspection list. RFP to renew will be issued soon.
- Contractors hired consultants to do the QC as part of their contracts.

4. Q&A

- a. Quality of plans coming from consultants? There's work to be done on both sides. Philosophy is changing quickly – everyone is thinking differently (bike lanes, less impact/intrusion). More clarity can come from the city on standards, small opportunities for improvements. What is needed most is trust. Due to City's understaffing, the City needs to be able to count on quality reviews coming from consultants. Consistency and leadership is needed now more than ever.
- b. Alt Delivery? The City is going in that direction. The City has to be nimble in different methods of delivery, the public doesn't care that the city is understaffed, recognition that there has to be evolution of thought in this, different models (D-B) are being studied as options. Many grants are starting to prefer it. New leadership is looking at solutions. ACEC helping to educate leadership on how the new/different models work and can work.
- c. World Cup? We'll have a dry run with the NFL draft, how do we get ready for this in terms of transportation? What is the solution, but first, what is the problem?
- d. Inflation? What is the impact? Everything is going overbudget. Supply issues – especially in concrete. Discipline on the consulting side – “real price” is more important than ever, preference is to have the real price and not be able to do the job. Bridges 30-40% up in price. Lead time on the LEDs, pipes, etc. holding up projects.

- e. CREO – old HRD department headed up by Andrea Dorch, how can the process be streamlined for DBE (too arduous for a small business).
- f. RFP/RFQ process – as everyone continues to be busy, there is a need to be more proactive/organized (consultants trying to plan what is in their pipeline), notification as RFPs/Qs come out? The City is exploring the use of an IDIQ process to prequal and get firms contracted so that the lengthy contracting process can be shortened and made more efficient.

5. Plan for Next Meeting

We'll reach out for ideas. Maybe a late January/early February option. Water Department seems like a good next deep dive.

Director
Public Works Director
Michael Shaw
205382

Deputy Director
Transportation Director
Jason Waldron
60208928

Construction
Utility Manager
Associate Director Construction
Mark Montgomery
60209438

Multimodal
Utility Manager
Associate Director Transportation
Angela Laurie
203971

Engineering
Assistant Engineering Director
City Engineer
Nicolas Bosonetto
60208002

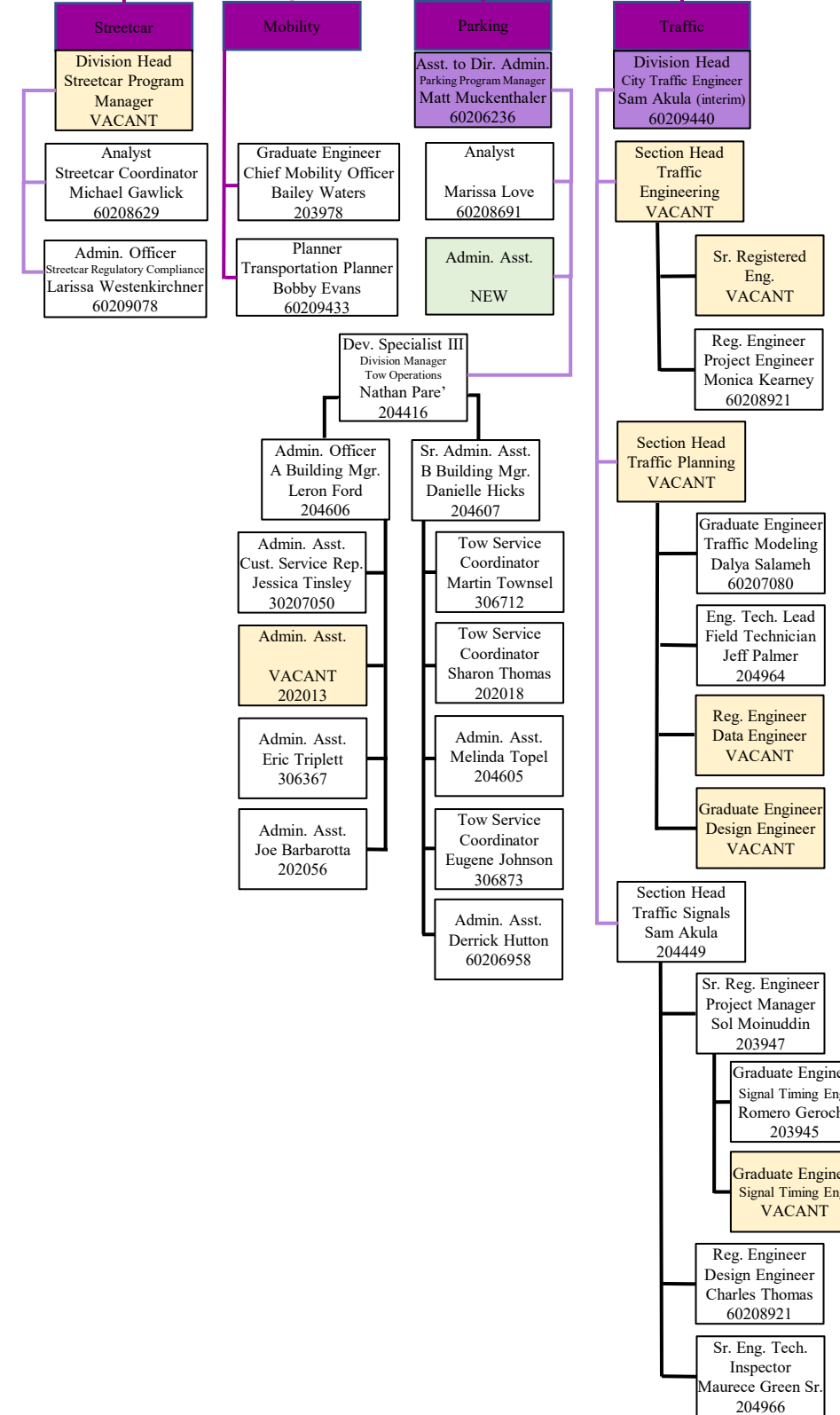
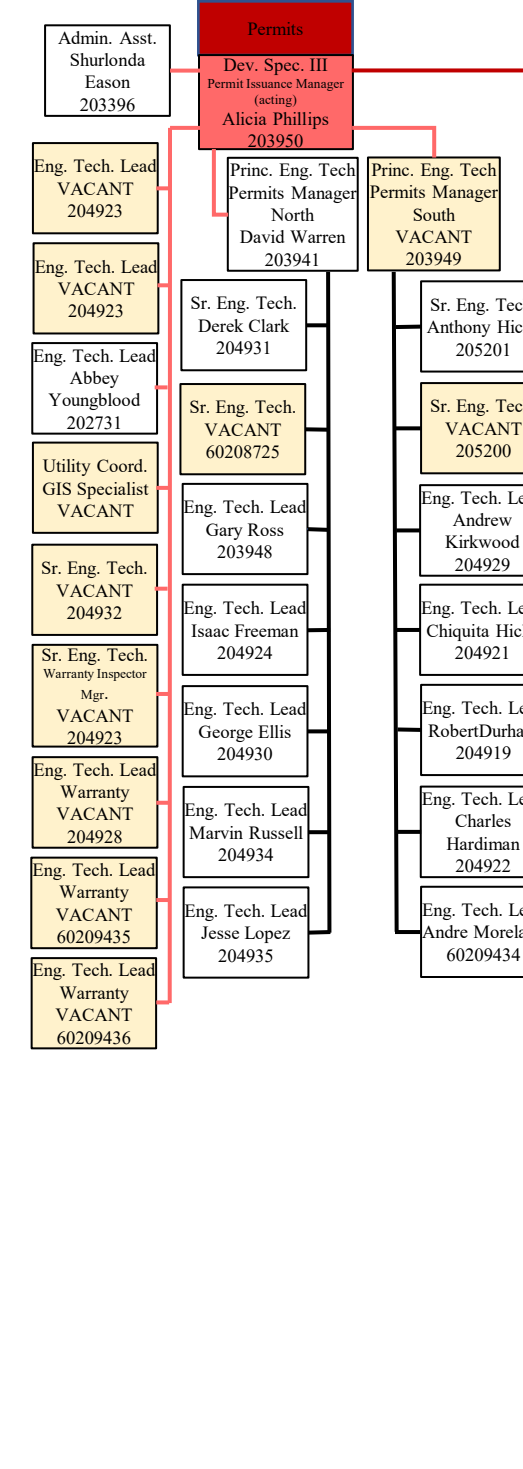
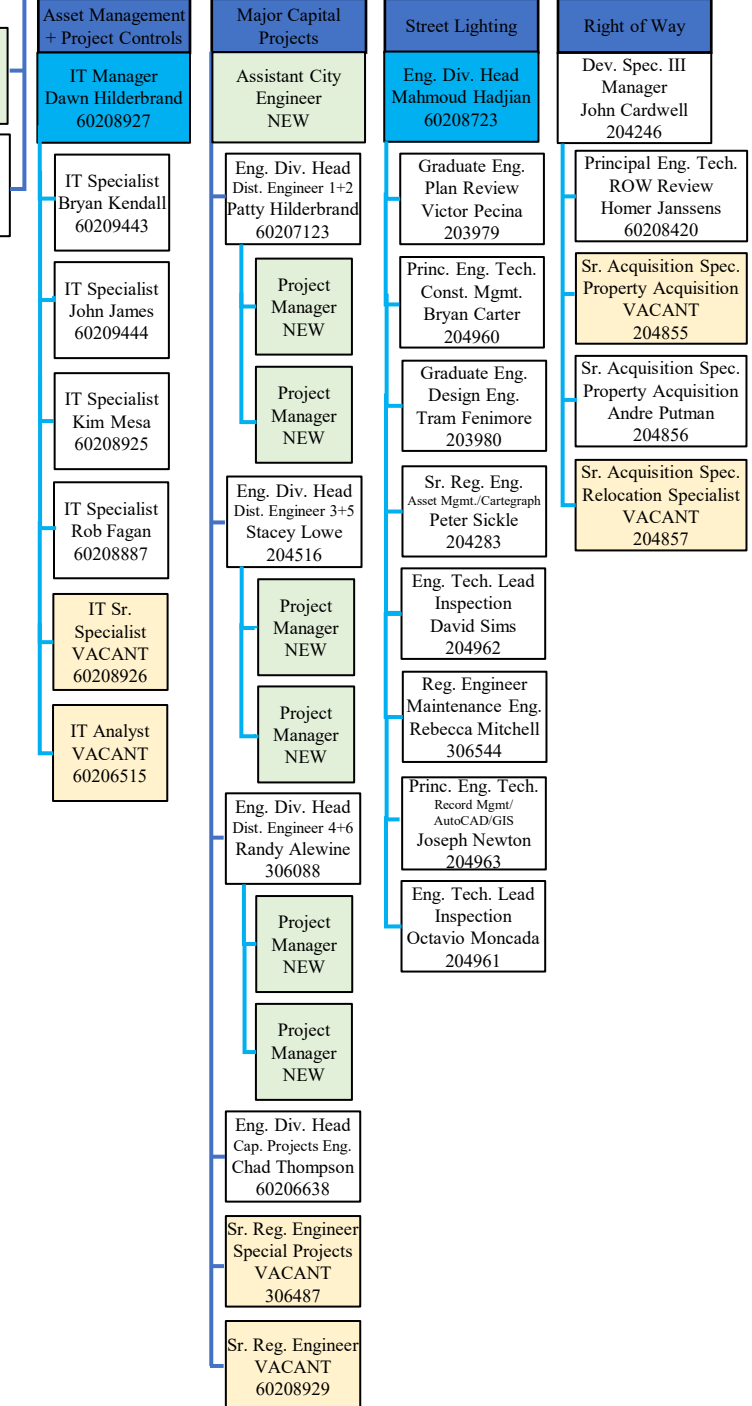

Denotes Vacant Positions Denotes New Positions